



City of Raymond

WASHINGTON

CITY COUNCIL AGENDA

Meeting: Monday, March 20th, 2023, at 6:00 PM City Hall
Location: Council Chambers
ZOOM LINK: https://us02w_eb.zoom.us/j/5780540411

Meeting ID: 578 054 0411
One tap mobile 1-253-215-8782, 2590939124# US (Tacoma)

If you would like to be added to our "Speakers List" your request must be received by 4:00 pm on March 20th, 2023.

*Your request must include the following: meeting date, your first and last name, city of residence, agenda item(s) that you would like to provide comment on, and the telephone number you will be calling from. Please email this information to clerk@cityofraymond.com. *Please note that the information you provide may be subject to disclosure pursuant to Washington State's Public Record Act, chapter 42.56 RCW.*

1. **CALL TO ORDER**
2. **PLEDGE OF ALLEGIANCE**
3. **ROLL CALL AND DETERMINATION OF A QUORUM**
4. **OATH OF OFFICE- POLICE CHIEF & OFFICER**
5. **APPROVAL OF AGENDA, CONSENT AGENDA, AND THE MINUTES OF MARCH 6TH, 2023,
REGULAR COUNCIL MEETING**
6. **CORRESPONDENCE**
7. **ITEMS FROM THE PUBLIC**
 - a. **Rene Forsberg- Keller Williams Premier Partners (April Fair Housing Month)**
8. **PROCLAMATION: APRIL 2023 FAIR HOUSING MONTH**
9. **ORDINANCE #1920: AN ORDINANCE OF THE CITY OF RAYMOND, WASHINGTON, AMENDING
SECTION 2.65.020 OF THE RAYMOND MUNICIPAL CODE RELATING TO CIVIL SERVICE
MEMBERSHIP- *Second Reading***
10. **CONFIRMATION OF CHUCK SPOOR TO CIVIL SERVICE BOARD- *Action***
11. **APPROVAL OF 2023 SPRING CLEAN-UP- *Action***

Next Regular Scheduled Council Meeting

MONDAY, APRIL 3RD, 2023, at 6:00 PM

Notice – All proceedings of this meeting are sound recorded – Except Executive Sessions – The City of Raymond provides access and services to all members of the public. Please notify City Hall at least 48 hours prior to an event if reasonable accommodations are needed.



City of Raymond

WASHINGTON

12. **VISITOR'S CENTER**
13. **RV PARK CONDITIONAL USE PERMIT**
14. **COUNCIL COMMITTEE DISCUSSION- *(Tabled from 2/21/22 meeting)***
15. **DEPARTMENT HEAD REPORTS**
 - a. Fire Chief Bill Didion
 - b. Police Chief Pat Matlock
 - c. Public Works Director Eric Weiberg
 - d. Clerk- Treasurer Kayla MacIntosh
16. **MAYOR'S REPORT**
17. **PUBLIC COMMENT ON CURRENT AGENDA ITEMS**
18. **COUNCIL COMMENTS**
19. **FUTURE AGENDA TOPICS**
20. **ADJOURNMENT**

Next Regular Scheduled Council Meeting

MONDAY, APRIL 3RD, 2023, at 6:00 PM

Notice – All proceedings of this meeting are sound recorded – Except Executive Sessions – The City of Raymond provides access and services to all members of the public. Please notify City Hall at least 48 hours prior to an event if reasonable accommodations are needed.



City of Raymond

WASHINGTON

COUNCIL PROCEEDINGS

MARCH 6th, 2023

CALL TO ORDER

The council meeting was called to order at 6:00 p.m. by Mayor pro tempore Steve Jones. Roll was taken and the meeting was quorate.

Council Members present:

Karen Tully
Heidi Worlton
Chris Halpin
Tony Nordin
W. Ian Farrell
Steve Jones

Council Members Absent:

Ryan Porter (Absent- Unexcused)

Department Heads Present:

Kayla MacIntosh, Clerk/Treasurer
Bill Didion, Fire Chief
Eric Weiberg, Public Works Director
Chuck Spoor, Chief of Police

4. APPROVAL OF AGENDA, CONSENT AGENDA & MINUTES

Councilor Tully moved to approve the agenda, consent agenda for tonight's meeting, as well as the minutes of February 21st, 2023, meeting. Motion carried. Motion passed with 6 ayes and 1 absence.

APPROVAL OF CLAIMS

CLAIMS #71355 THROUGH #71386

\$42,295.58

**PAYROLL #71348 THROUGH #71354
(Direct Deposit included)**

\$164,037.27

5. CORRESPONDENCE:

There was none.

6. ITEMS FROM THE PUBLIC

1. Pacific County EDC provided an annual presentation for the council.
2. Citizens Paul Delau and Barbara Hannah from Sunday Afternoon Live discussed heating issues at the Raymond Theatre
3. Citizen Ky Han discussed modifying his RV park plan.

4. Citizen Ezra McCampbell advised council of the local homeless camp issues.

7. ORDINANCE #1920: AN ORDINANCE OF THE CITY OF RAYMOND, WASHINGTON, AMENDING SECTIONS 2.65.020 OF THE RAYMOND MUNICIPAL CODE RELATING TO CIVIL SERVICE MEMBERSHIP- *First Reading*

Councilor Halpin moved to approve Ordinance #1920 to a second reading. Motion Carried. Motion passed with 6 ayes and 1 absence.

8. DEPARTMENT HEAD REPORTS:

- Fire Chief, Bill Didion, advised of the Civil Service Testing for fire Friday March 10th, 2023
- Police Chief, Pat Matlock, provided a staffing update for the new academy graduate and discussed concerns of local homeless encampment.
- Public Works Director, Eric Weiberg, provided both a Parks Plan and water tank rehab project update.
- Clerk/ Treasurer, Kayla MacIntosh, advised council of a grant award for Cyber Security as well as provided a staffing report and plan for maternity leave.

13. MAYOR'S REPORT:

There was none.

14. PUBLIC COMMENT ON CURRENT AGENDA ITEMS

There were none.

15. COUNCIL COMMENTS:

Councilor Farrell discussed fire code regarding the lock doors during theatre performances.

16. FUTURE AGENDA TOPICS:

Water Fluorination

17. ADJOURNMENT:

The meeting was adjourned by motion of Council Member Farrell at 6:43 p.m. Motion carried. Motion passed with 6 ayes and 1 absence.

ATTEST:

Kayla MacIntosh, Clerk/ Treasurer

Dee Roberts, Mayor



RAYMOND CITY COUNCIL MEETING

MARCH 20TH, 2023

CONSENT AGENDA

APPROVAL OF CLAIMS

CLAIMS #71388 THROUGH #71390

CLAIMS #71397 THROUGH #71455

\$648,643.03

PAYROLL #71391 THROUGH #71396

(Direct Deposit included)

\$205,046.93

FEBRUARY EFT/ DEBIT

\$21,791.03



A/P Check Register

Fiscal : 2023
 Period : 2023 - March 2023
 Council Date : 2023 - March 2023 - 2nd Council

Number	Vendor Name	Account Description	Amount
71388	LIGHT IN MOTION SHOW CONTROL, LLC	Miscellaneous	\$27,379.03
			THEATER LIGHTING
71389	MACINTOSH, KAYLA	Training	\$367.70
			TRAINING PER DIEM
71390	WEIBERG, ERIC	Training/Travel	\$453.59
			TRAINING PER DIEM
71397	911 SUPPLY	Operating Supplies	\$136.20
			POLICE UNIFORMS
71398	ABERDEEN O. E.	Lease Rental - Landfill	\$22.24
		Operating Rentals & Leases	\$22.24
		Operating Rentals/Leases	\$44.46
		Rentals & Leases	\$66.72
		Check Total:	\$155.66
			CH COPIER
71399	Aberdeen Office Equipment	Operating Leases/Rentals	\$113.17
		Operating Rentals & Leases	\$141.84
		Operating Rentals/leases	\$202.88
		Operating Supplies	\$66.44
		Professional Services	\$27.03
		Rental Copier	\$96.44
		Rentals & Leases	\$418.64
		Salaries & Wages	\$66.44
		Check Total:	\$1,132.88
			CH PRINTER/COPIER
71400	ABILITY NETWORK INC.	Professional Services	\$172.70
			AMBULANCE CLAIMS
71401	Airgas USA, LLC	Operating Supplies	\$45.70
			FIRE/AMB OXYGEN
71402	BARNHART HOME CLEANING	Prof Services (Janitor)	\$1,200.00
			LIBRARY CLEANING
71403	BEANS & ROCKS, LLC	Distribution Supplies	\$593.14
		Operating Supplies	\$1,086.93
		Check Total:	\$1,680.07
			ALL DEPT ROCK
71404	Borden's Auto Parts	Distribution Supplies	\$43.47
		Operating Supplies	\$1,452.27
		Repair & Maintenance	\$86.45
		Check Total:	\$1,582.19
			ALL DEPT SUPPLIES
71405	CenturyLink	Communications	\$95.47
			WWTP PHONE/INTERNET
71406	CH2M Hill, Inc.	Miscellaneous-Tank Rehab Pending Loan Approval	\$9,118.08
		Repair & Maintenance(Inc. PW shop roof, office,carport and paving for Willapa Center alley)	\$927.32
		Check Total:	\$10,045.40
			WATER TANK REHAB
71407	CINTAS FIRE 636525	Professional Services	\$349.13
			FIRE EXTINGUISHER MAINTENANCE

71408	Coast Controls & Automation, Inc.	Instrument Services	\$1,075.60	
		Instrumentation Services	\$13,331.97	
			Check Total:	\$14,407.57 WWTP/WTP REPAIRS
71409	Culligan	Operating Rentals/leases	\$48.49	
		Rentals & Leases	\$48.65	
			Check Total:	\$97.14 ALL DEPT WATER
71410	Dennis Company	Distribution Supplies	\$450.90	
		Office Supplies	\$16.17	
		Operating Supplies	\$2,774.27	
		Repair & Maintenance	\$20.60	
		Supplies	\$21.07	
			Check Total:	\$3,283.01 ALL DEPT SUPPLIES
71411	Dilk Tire Service	Distribution Supplies	\$184.93	
		Operating Supplies	\$369.85	
		Professional Services	\$124.32	
		Repair & Maintenance	\$351.91	
		Repairs & Maintenance (Inc. PW Roof, office, carport)	\$760.46	
			Check Total:	\$1,791.47 ALL DEPT SERVICE/MAINTENANCE
71412	Edge Analytical, Inc.	Lab Tests	\$157.00	WTP LABS
71413	Election Reserve Fund #117	Voters Registration Costs	\$11,599.34	VOTER COSTS
71414	Englund Marine & Industrial Supply	Distribution Supplies	\$118.59	
		Operating Supplies	\$1,791.70	
			Check Total:	\$1,910.29 ALL DEPT SUPPLIES
71415	Enviro-Clean Equip., Inc.	Distribution Supplies	\$171.34	
		Operating Supplies	\$342.68	
			Check Total:	\$514.02 WWTP SUPPLIES
71416	EVANS MARINE SOLUTIONS	Professional Services	\$4,188.24	KAYAK LAUNCH/DOCK
71417	Ferrellgas	Fuel	\$2,799.32	
		Fuel Consumed	\$1,966.69	
			Check Total:	\$4,766.01 ALL DEPT PROPANE
71418	Flannery Publications, Inc.	Professional Services	\$1,283.34	NEWSPAPER ADS
71419	G.H. Equipment Co.	Operating Supplies	\$48.80	WWTP SUPPLIES
71420	Hatfield Communications	Professional Services	\$719.95	CH PHONE SERVICES
71421	Henry Schein, Inc.	Operating Supplies	\$1,584.79	AMB SUPPLIES
71422	IPMA-HR	Professional Services	\$550.00	FIRE/AMB TESTING
71423	JOINT PACIFIC COUNTY HOUSING AUTHORITY	CDBG Willapa Center Exp	\$492,784.00	CDBG GRANT - APTS
71424	KARNATZ, JEFF	Operating Supplies	\$799.82	SUPPLY REIMBURSEMENT
71425	KIMBALL MIDWEST	Distribution Supplies	\$42.97	
		Operating Supplies	\$128.91	
			Check Total:	\$171.88
71426	Lemay Mobile Shredding	Professional Services	\$183.00	ALL DEPT SHREDDING
71427	Maneman Electric	Repair & Maintenance (including exterior paint)	\$441.22	LIBRARY REPAIRS
71428	MB INDUSTRIAL MOTORS, LLC	Repair & Maintenance(Inc. PW shop roof, office, carport and paving for Willapa Center alley)	\$2,732.87	WTP REPAIRS

71429	Morley, Brian	Training	\$91.70	MILEAGE REIMB
71430	One Call Concepts, Inc.	Misc (Dues, Registrations etc)	\$1.98	
		Other Miscellaneous	\$1.98	
		Check Total:	\$3.96	WWTP/WTP ALERTS
71431	Pacific County EDC	Col-Pac RC&D Dues	\$2,400.00	ANNUAL DUES
71432	Pacific County Sheriff	County Jail Services	\$942.50	POLICE JAIL FEES
71433	PETROCARD INC.	Fuel	\$1,882.86	
		Fuel Consumed	\$3,109.20	
		Check Total:	\$4,992.06	ALL DEPTS FUEL
71434	Pitney Bowes	Operating Rentals & Leases	\$23.55	
		Operating Rentals/Leases	\$70.63	
		Rental Copier	\$23.54	
		Rentals & Leases	\$70.65	
		Check Total:	\$188.37	ALL DEPTS POSTAGE MACHINE
71435	POWERDMS, INC.	Professional Services	\$1,921.48	POLICE SOFTWARE SUBSCR.
71436	PUD #2 of Pac. Co.	P.u.d. Utilities	\$2,769.60	
		Pool Utilities	\$48.95	
		Public Market Utilities	\$89.43	
		Public Utilities	\$411.57	
		Public Utility Service	\$822.59	
		Seaport Utilities	\$348.93	
		Utilities	\$13,543.00	
		Utility Services	\$1,233.37	
		Visitor Center Utilities	\$90.25	
		Check Total:	\$19,357.69	ALL CITY PUD
71437	PUMPTECH, INC.	Operating Supplies	\$4,629.70	WWTP SUPPLIES
71438	Quill Corporation	Office Supplies	\$283.29	POLICE/WTP SUPPLIES
71439	Ricoh USA, Inc	Lease/rental	\$24.81	
		Operating Rentals & Leases	\$24.82	
		Operating Rentals/Leases	\$24.82	
		Rental Copier	\$24.82	
		Rentals & Leases	\$186.55	
		Check Total:	\$285.82	FIRE/PW COPIER
71440	Ricoh USA, Inc	Operating Rentals/leases	\$4.36	
		Rentals & Leases	\$18.23	
		Check Total:	\$22.59	FIRE/POLICE COPIES
71441	Royal Heights Transfer	Biosolids Disposal	\$323.50	
		Lease Rental - Landfill	\$15,138.40	
		Check Total:	\$15,461.90	ALL CITY GARBAGE
71442	SNURE SEMINARS	Training	\$150.00	FIRE/AMB WEBINAR
71443	South Bend Pharmacy	Communications	\$13.18	WTP SHIPPING
71444	Standard Insurance Co	Personnel Benefits	\$326.22	
		Volunteer Benefits	\$231.12	
		Water Treatment Benefits	\$23.55	
		Check Total:	\$580.89	ALL EMPLOYEE INS
71445	Steve's Front End Inc.	Repair & Maintenance	\$1,754.57	AMB/POLICE REPAIRS
71446	Stryker Sales Corporation	Small Tools & Equipment	\$1,111.65	FIRE SUPPLIES

71447	THRIFTWAY ON THE WILLAPA	Distribution Supplies	\$24.01	
		Operating Supplies	\$72.03	
				Check Total: \$96.04 ALL DEPT SUPPLIES
71448	U.S. Cellular	Communications	\$227.59	PW/FIRE CELL PHONES
71449	ULINE	Supplies	\$228.89	PARKS SUPPLIES
71450	UniFirst	Laundry	\$839.16	
		Laundry Service	\$480.26	
		Misc (Dues, Registrations etc)	\$186.12	
		Miscellaneous	\$103.41	
				Check Total: \$1,608.95
				ALL DEPT LAUNDRY SERVICE
71451	USA Blue Book	Lab Supplies	\$458.25	
		Lab Tests	\$41.99	
				Check Total: \$500.24 WTP/WWTP SUPPLIES
71452	WA Assoc. of Sheriffs & Police Chiefs	Training Tuition	\$75.00	POLICE DUES
71453	WA ST Dept of Ecology - Attn: Cashiering Unit	Miscellaneous (Dues, Fees etc)	\$67.00	DAVE FRASIER TESTING FEE
71454	Willapa Harbor Chamber of Commerce	Facility Supplies	\$120.00	
		Lodging Tax - Outreach/Advertising	\$2,632.01	
				Check Total: \$2,752.01 LODGING TAX FUND - PLANTARS
71455	Willapa Printing	Office Supplies	\$86.48	POLICE SUPPLIES
		Grand Total	\$648,643.03	
		Total Accounts Payable for Checks #71388 Through #71455		

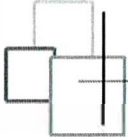

Register

Number	Name	Fiscal Description	Cleared	Amount
71391	Boggs, Arie H.	2023 - March 2023 - 1st Council		\$3,107.88
71392	Ristow, Micah D.	2023 - March 2023 - 1st Council		\$2,389.81
71393	I.A.F.F. (GNWFCU)	2023 - March 2023 - 1st Council		\$799.68
71394	OREGON DEPT. OF JUSTICE	2023 - March 2023 - 1st Council		\$339.00
71395	WSCCCE	2023 - March 2023 - 1st Council		\$1,049.75
71396	WSCFF/DiMartino Associate	2023 - March 2023 - 1st Council		\$552.38
<u>AFLAC MARCH 1ST</u> <u>PAYROLL 2023</u>	AFLAC Remittance Processing	2023 - March 2023 - 1st Council		\$1,239.55
<u>BPAS/VEBA MARCH 1ST</u> <u>PAYROLL 2023</u>	BPAS VEBA	2023 - March 2023 - 1st Council		\$1,895.77
<u>DEF. COMP MARCH 1ST</u> <u>PAYROLL 2023</u>	WA St Treasurer - Def Comp	2023 - March 2023 - 1st Council		\$4,524.51
<u>ESD MARCH 1ST</u> <u>PAYROLL 2023</u>	Employment Security Dept	2023 - March 2023 - 1st Council		\$267.13
<u>IRS TAXES MARCH 1ST</u> <u>PAYROLL 2023</u>	Raymond City Treasurer- Taxes	2023 - March 2023 - 1st Council		\$33,287.62
<u>L&I MARCH 1ST</u> <u>PAYROLL 2023</u>	Dept of Labor & Industry	2023 - March 2023 - 1st Council		\$4,547.43
<u>MARCH 1ST PAYROLL</u> <u>2023</u>	Payroll Vendor	2023 - March 2023 - 1st Council		\$85,925.01
<u>NATIONWIDE MARCH</u> <u>1ST PAYROLL 2023</u>	Nationwide Retirement Solutions	2023 - March 2023 - 1st Council		\$300.00
<u>NW ADMIN MARCH 1ST</u> <u>PAYROLL 2023</u>	Northwest Administrators	2023 - March 2023 - 1st Council		\$50,552.80
<u>NWFFT MARCH 1ST</u> <u>PAYROLL 2023</u>	NORTHWEST FIRE FIGHTERS TRUST	2023 - March 2023 - 1st Council		\$13,436.08
<u>PFMLA MARCH 1ST</u> <u>PAYROLL 2023</u>	Employment Security Dept (PFMLA)	2023 - March 2023 - 1st Council		\$777.40
<u>VIMLY MARCH 1ST</u> <u>PAYROLL 2023</u>	Vimly Benefit Solutions, Inc.	2023 - March 2023 - 1st Council		\$55.13
				\$205,046.93

Register Activity

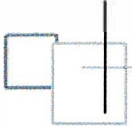

Fiscal: 2023
 Period: 2023 - February 2023
 Council Date: 2023 - February 2023 - Open Period

Reference	Date	Amount	Notes
Reference Number: 4TH QTR. 2022 LEASEHOLD EXCISE TAX	WA ST Dept of Revenue	\$471.10	
<u>4TH QTR. 2022 LEASEHOLD EXCISE TAX</u>	2/1/2023	\$471.10	
Reference Number: DOR EXCISE TAX FEB 2023	WA ST Dept of Revenue	\$11,674.77	
<u>DOR EXCISE FEB 2023</u>	2/7/2023	\$11,674.77	
Reference Number: INVOICE CLOUD MONTHLY FEES FEB. 2023	ICLOUD	\$279.00	
<u>INVOICE CLOUD MONTHLY FEES FEB 2023</u>	2/8/2023	\$279.00	
Reference Number: MASTERCARD FEB 2023	MASTERCARD C/O FIRST INTERSTATE BANK	\$6,828.14	
<u>MASTERCARD FEB 2023</u>	2/21/2023	\$6,828.14	
Reference Number: POLICE CAR LOAN #2 FEB. 2023	Bank of the Pacific	\$865.54	
<u>POLICE CAR LOAN #2 FEB. 2023</u>	2/10/2023	\$865.54	
Reference Number: POLICE CAR LOAN #3 FEB. 2023	Bank of the Pacific	\$924.67	
<u>POLICE CAR LOAN #3 FEB. 2023</u>	2/19/2023	\$924.67	
Reference Number: POLICE CAR LOAN #4 FEB 2023	Bank of the Pacific	\$747.81	
<u>POLICE CAR LOAN #4 FEB. 2023</u>	2/10/2023	\$747.81	

OATH OF OFFICE

STATE OF WASHINGTON } SS.
COUNTY OF PACIFIC }

I, PATRICK MATLOCK, do solemnly swear that I will support the Constitution of the United States of America, the Constitution and laws of the State of Washington, and the Ordinances of the City of Raymond, and that I will faithfully and impartially perform and discharge the duties of the office of POLICE CHIEF according to the law, to the best of my ability.

Subscribed and sworn to before me this 20TH day of March 2023.

Kayla MacIntosh, Clerk/Treasurer
City of Raymond

OATH OF OFFICE

STATE OF WASHINGTON } SS.
COUNTY OF PACIFIC }

I, LUCAS MARTHALLER, do solemnly swear that I will support the Constitution of the United States of America, the Constitution and laws of the State of Washington, and the Ordinances of the City of Raymond, and that I will faithfully and impartially perform and discharge the duties of the office of POLICE OFFICER according to the law, to the best of my ability.

Subscribed and sworn to before me this 20TH day of March 2023.

Kayla MacIntosh, Clerk/Treasurer
City of Raymond

**PROCLAMATION
APRIL 2023
FAIR HOUSING MONTH**

WHEREAS On April 11, 1968, the Fair Housing Act was enacted into law, recognizing that no American should have their right to purchase or rent shelter of choice abridged because of race, color, religion, sex, handicap, familial status, national origin, sexual orientation, or gender identity.

WHEREAS The City of Raymond is committed to the mission and intent of Congress to provide fair and equal housing opportunities for all; and

WHEREAS equality of opportunity for all is a fundamental policy of this nation and our state and our community; and

WHEREAS the location that people live has a direct impact on the quality of their health, education, and access to economic opportunities; and

WHEREAS Discriminatory housing practices create racial and economic segregation in communities that can lead to disparate outcomes in overall quality of life; and

WHEREAS the City of Raymond believes that access to fair housing laws have made our communities stronger and more vibrant in Washington State; and

WHEREAS we are committed to programs that will help educate the public about the right to equal housing in the State of Washington; and

WHEREAS we are committed to promoting housing choices and fostering inclusive communities free from housing discrimination

NOW THEREFORE, BE IT RESOLVED, this 21st day of February 2023, that the City of Raymond celebrate and Proclaim the Month of April 2023 as Fair Housing Month and thank the many people in our communities who aspire to open the doors of opportunity of housing to all people free from any discrimination.

Dee Roberts, Mayor

Attest;
Kayla MacIntosh, Clerk-Treasurer

ORDINANCE NO. 1920

AN ORDINANCE OF THE CITY OF RAYMOND, WASHINGTON, AMENDING SECTION 2.65.020 OF THE RAYMOND MUNICIPAL CODE RELATING TO CIVIL SERVICE MEMBERSHIP REQUIREMENTS.

WHEREAS, the City of Raymond created a civil service commission which substantially accomplishes the purpose of RCW Title 41; and

WHEREAS, the City Council finds that eliminating the requirement to be a resident of the city to be appointed as a member of the commission is in the best interest of the public, civil service commission, and city.

NOW, THEREFORE, BE IT ORDAINED BY THE CITY COUNCIL OF THE CITY OF RAYMOND, WASHINGTON, AS FOLLOWS:

Section 1. Repeal Section 2.65.020, "Membership compensation requirements," of the Raymond Municipal Code (RMC) and replace with the following revised Section 2.65.020, "Membership compensation requirements":

2.65.020 Membership compensation requirements.

The members of the civil service commission shall be appointed by the mayor; provided that the members of the commission presently constituted shall continue in office until the term of their current appointment expires. The members of the commission shall serve without compensation. No person shall be appointed a member of the commission who is not a citizen of the United States and an elector of Pacific County.

Section 2. If any portion of this ordinance is held to be invalid or unconstitutional for any reason, such finding shall not affect the remainder of the Ordinance, which shall remain in full force and effect.

Section 3. This ordinance shall be in full force and effect five (5) days after its passage and publication as provided by law.

INTRODUCED AND PASSED THIS 20th DAY OF MARCH 2023.

Dee Roberts, Mayor

Attest:

City Clerk/Treasurer

Chapter 2.65 CIVIL SERVICE

2.65.020 Membership compensation requirements.

The members of the civil service commission shall be appointed by the mayor; provided, that the members of the commission presently constituted shall continue in office until the term of their current appointment expires. The members of the commission shall serve without compensation. No person shall be appointed a member of the commission who is not a citizen of the United States, ~~a resident of the city for at least three years immediately preceding such appointment,~~ and an elector of Pacific County.



City of Raymond

SPRING CLEANUP

April 10 - 15, 2023

For Residential Garbage Account Holders Only



DISPOSE OF YOUR EXCESS WASTE

- Raymond residents may take **ONE** free pickup load of "**general waste**" to Royal Heights Transfer Station between 10 AM and 2 PM, Monday, April 10th thru Saturday, April 15th, 2023.
- A current City of Raymond garbage bill must be presented to Royal Heights at time of delivery as confirmation of service.
- Customers will be required to pay Royal Heights for brush, tires, mattresses, and appliances.

FOR A FEE - THE CITY CAN DISPOSE OF YOUR EXCESS WASTE

(see "Fee Listing" below)

- FOR CITY COLLECTION – You must call City Hall at 942-4100 before Thursday, April 6, 2023.
- Separate items, i.e. brush, metals, general waste, tires, etc.
- Place trash near your normal collection point on your normal collection day.
- Hazardous materials (paints, oils, batteries, etc.) will not be collected. Call Pacific County DCD at 875-9356 for hazardous materials disposal.

FEE LISTING

(Charges will be added to your next Utility Bill)

General Waste (per 100 lbs - estimated)	\$10.00
Brush Pile (4'x4'x4') Limit 1 Pile per customer	\$5.00
Per car tire without rim	\$5.00
Per truck tire without rim	\$10.00
Add per tire with rim	\$5.00
Per appliance	\$30.00

Publish: March 29, 2023

STAFF REPORT

TO: MAYOR & CITY COUNCIL
FROM: DEPARTMENT OF PUBLIC WORKS
DATE: March 13, 2023
SUBJECT: RV Park Conditional Use Permit

BACKGROUND: The Owner of the chevron Mr. Kyung Suk Han was in attendance at the regular scheduled March 6th council meeting to ask to deviate from his conditional use permit. Mr. Han would like to construct a different type of fence and not do the landscaping. The city council asked him to work with the planning department and bring information back to the city council.

The city staff has compiled the relevant information for the city council to review. The approved Raymond RV Park Design includes a landscaping plan and the fence detail. A copy of the conditional use permit is included.

City of Raymond



Public Works Department

300 First Street

Raymond, WA 98577-2427

CONDITIONAL USE PERMIT

DATE OF ISSUE: 3/5/2019

Council Approved: 3/4/2019

APPLICANT: Mr. Kyung Suk Han

SITE: 622 Heath Street/Chevron 101 Quick Stop

PERMISSION TO: Construct and Operate RV Park & Campground

FINDINGS & CONCLUSIONS: Per RMC Chapter 15.44, Allowed and Restricted Uses Table, RV parks and campgrounds require a conditional use permit. The City of Raymond received a complete Conditional Use Permit Application from Mr. Kyung Suk Han on October 23, 2018 requesting to reconstruct and expand his RV park located at 622 Heath Street, the Chevron 101 Quick Stop. A Notice of Application and Public Hearing was advertised in the Willapa Harbor Herald on October 31, 2018 and mailed to abutting property owners within 300-feet of the proposed site on October 30, 2018.

The planning commission (PC) conducted a public hearing on November 13, 2018, at which the commissioners considered the application and related materials, city planner's report, and staff and applicant comments. No comments were received from the public for the record. The PC established that RV parks are regulated by the Pacific County Board of Health's Ordinance No. 5.

The City Council considered the application and related materials at their regular meeting held on December 17, 2018 and on March 4, 2019. The City Council established that the use conforms generally to the objectives of the comprehensive plan and the intent of RMC Chapter 15.48, Conditional Uses; such uses will not be materially detrimental to the nearby affected properties or their occupants; and such uses meet the overall density coverage, yard, height, and all other regulations of the zoning district in which it is located. The above described use has been approved by the City Council with the following conditions which are subject to City approval prior to issuance of an Occupancy Permit:

1. Compliance with the Pacific County Board of Health Ordinance No. 5;
2. Completion of a 6-foot high perimeter fence along the portions of the RV Park that abut SR6 and SR101, design and construction to be approved by City Council;
3. Landscaping on the outside of the 6-foot perimeter fence, as approved by City Council; and
4. The length of stay at the RV Park shall be limited to 90-days in any 180-day period.

Signature Tony Nordin Date 3-28-2019
(Tony Nordin, Mayor)

c/c: Mr. Kyung Suk Han, Applicant
Scott Pearson, Public Works Administrator

PHONE 360-942-4108 · FAX 360-942-4138 · EMAIL raymondpw@cityofraymond.com

Back Flow Preventer Required

R22004
 Building Plans Approved
 As per Noted Corrections
SCW
 City of Raymond Building Department

RAYMOND RV PARK DESIGN

SECTION 19, TOWNSHIP 14 N, RANGE 8 W, WILLAMETTE MERIDEN

PREPARED FOR:

KAY HAN



RV PARK PRELIMINARY DESIGN
 622 HEATH STREET
 RAYMOND, WASHINGTON 98677

PROJECT CONTACTS

CLIENT KAY HAN 622 HEATH STREET RAYMOND, WASHINGTON 98677 P: 360.876.5633	CIVIL ENGINEER HYDRONUM, LLC 314 W 15TH STREET VANCOUVER, WASHINGTON 98660 P: 360.589.4336 LINSEY.CROSSY@HYDRONUM.COM
SURVEYOR STERLING SURVEYING PO BOX 152 RAYMOND, WASHINGTON 98677 P: 360.876.4016	CONTRACTOR ADDRESS ENVIRONMENTAL CONTRACTING, LLC 765 COLORADO STREET KESWIC, WASHINGTON 98628 P: 360.577.1554 SCOTT@ADDRESS.COM SCOTT@ADDRESS.COM

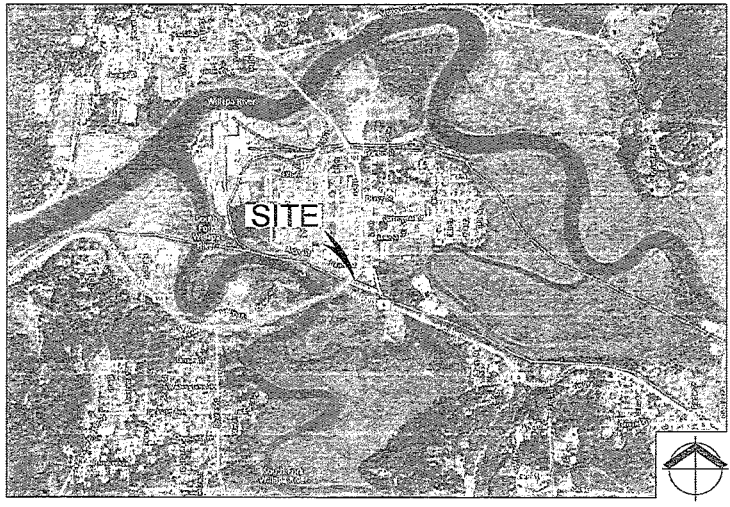

VICINITY MAP

1" = 1,000'

SHEET INDEX

- S0.0 COVER SHEET
- S0.1 CONSTRUCTION NOTES
- S0.2 MASTER LEGEND
- S1.0 EXISTING CONDITIONS PLAN
- S2.0 SITE PLAN
- S3.0 UTILITY SANITARY SEWER PLAN
- S4.0 DRAINAGE PLAN
- S6.0 LANDSCAPING PLAN
- S6.0 DETAILS I
- S6.1 DETAILS II
- S6.2 DETAILS III
- S6.3 DETAILS IV

PROJECT SUMMARY

SITE ADDRESS:
 622 HEATH STREET
 RAYMOND
 PACIFIC COUNTY
 WASHINGTON, 98577

WORK DESCRIPTION:
 WORK WILL INCLUDE INSTALLATION OF 16 RECREATION VEHICLE (RV) CAMP SITES LOCATED SOUTH OF THE EXISTING CONVENIENCE STORE AND CHEVRON FUEL STATION. EACH CAMP SITE WILL INCLUDE A PAVED RV PADING AREA, A PAVED VEHICLE PARKING AREA, A LANDSCAPED AREA, AND POTABLE WATER, SEWER, AND ELECTRICAL HOOKUPS. A CENTRAL BATHROOM/SHOWER FACILITY WILL ALSO BE INSTALLED TO SUPPORT MIXING CAMPERS.

GENERAL NOTES

1. SURVEY PERFORMED BY STERLING SURVEYING IN 2018
2. CONTRACTOR TO VERIFY ALL UTILITY LOCATIONS AND DEPTHS PRIOR TO CONSTRUCTION. A MINIMUM OF TWO FULL BUSINESS DAYS PRIOR TO BEGINNING CONSTRUCTION, THE CONTRACTOR SHALL CALL 811 (UTILITY NOTIFICATION CENTER) FOR LOCATION MARK-UP OF EXISTING UTILITIES.
3. ALL CONSTRUCTION, MATERIALS, AND WORKMANSHIP SHALL CONFORM TO THE LATEST STANDARDS AND PRACTICES SET BY THE CITY OF RAYMOND AND THE LATEST EDITION OF THE "STANDARD SPECIFICATIONS FOR ROAD, BRIDGE, AND MUNICIPAL CONSTRUCTION" PREPARED BY WSDOT/APWA.
4. IN CASE OF A CONFLICT BETWEEN THE REGULATORY STANDARDS OR SPECIFICATIONS, THE MORE STRINGENT REQUIREMENT WILL PREVAIL.
5. ANY CHANGES TO THE DESIGN AND/OR CONSTRUCTION SHALL BE APPROVED BY THE OWNER OR ENGINEER.
6. APPROVAL OF THESE PLANS DOES NOT CONSTITUTE AN APPROVAL OF ANY OTHER CONSTRUCTION NOT SPECIFICALLY SHOWN ON THE PLANS.
7. A COPY OF THESE APPROVED PLANS SHALL BE ON THE JOB SITE WHENEVER CONSTRUCTION IS IN PROGRESS.
8. IT SHALL BE THE CONTRACTOR'S RESPONSIBILITY TO OBTAIN ALL CONSTRUCTION PERMITS AND PERMITS NECESSARY TO PERFORM THE WORK.
9. THE CONTRACTOR IS RESPONSIBLE FOR ALL CONSTRUCTION STAKING.
10. PUBLIC AND PRIVATE DRAINAGEWAYS SHALL BE PROTECTED FROM POLLUTION. NO MATERIAL IS TO BE DISCHARGED TO OR DEPOSITED IN STORMWATER SYSTEMS THAT MAY RESULT IN VIOLATION OF STATE OR FEDERAL WATER QUALITY STANDARDS.
11. ALL CONSTRUCTION WITHIN THE PUBLIC RIGHT-OF-WAY SHALL HAVE AN APPROVED PUBLIC RIGHT-OF-WAY WORK PERMIT PRIOR TO ANY CONSTRUCTION ACTIVITY WITHIN THE RIGHT-OF-WAY.
12. THE CONTRACTOR SHALL BE RESPONSIBLE FOR PROVIDING ADEQUATE SAFEGUARDS, SAFETY DEVICES, PROTECTIVE EQUIPMENT, FLAGGERS, AND ANY OTHER NECESSARY ACTIONS TO PROTECT THE LIFE, HEALTH, AND SAFETY OF THE PUBLIC, AND TO PROTECT PROPERTY IN CONNECTION WITH THE PERFORMANCE OF WORK COVERED BY THE CONTRACTOR. ALL TRAFFIC CONTROL DEVICES SHALL CONFORM TO THE LATEST ADOPTED EDITION OF THE "MANUAL ON UNIFORM TRAFFIC CONTROL DEVICES" (MUTCD) PUBLISHED BY THE U.S. DEPARTMENT OF TRANSPORTATION. TWO-WAY TRAFFIC MUST BE MAINTAINED AT ALL TIMES ON THE ADJACENT PUBLIC RIGHT-OF-WAY.
13. ANY PUBLIC PRIVATE CURB, GUTTER, SIDEWALK, OR ASPHALT DAMAGED DURING CONSTRUCTION SHALL BE REPAIRED TO THE CITY OF RAYMOND STANDARDS AND PRACTICES.
14. THE CONTRACTOR SHALL BE RESPONSIBLE FOR MAINTAINING THE INTEGRITY OF ADJACENT UTILITIES WHICH MAY INCLUDE, BUT ARE NOT LIMITED TO, WATER, SANITARY SEWER, STORMWATER, POWER, TELEPHONE, CABLE TV, GAS, IRRIGATION, AND STREET LIGHTING. THE CONTRACTOR SHALL NOTIFY RESIDENCES AND BUSINESSES 48 HOURS IN ADVANCE OF ANY WORK AFFECTING ACCESS OR SERVICE AND SHALL MINIMIZE INTERRUPTIONS TO DRIVERS AND FOR RESIDENTS AND BUSINESSES ADJACENT TO THE PROJECT.
15. ALL LAWN AND VEGETATED AREAS DISTURBED WILL BE RESTORED TO ORIGINAL CONDITION. ANY OBSERVABLE OR DAMAGE TO OTHER PROPERTY ON ADJACENT PARCELS OR IN THE PUBLIC RIGHT-OF-WAY SHALL ALSO BE REPAIRED OR RESTORED TO ORIGINAL CONDITION.



PERMITTING PLAN SET

COVER SHEET

S0.0

CONSTRUCTION NOTES

SITE GRADING

- ALL PORTIONS OF THE SITE WITHIN THE LIMITS OF THE WORK SHALL BE MOVED AND STRIPPED TO REMOVE ALL GRASS, ROOTS, ORGANIC SOIL, AND CONSTRUCTION FILL DEBRIS PRIOR TO THE BEGINNING OF ANY GRADING OPERATIONS, THE CONTRACTOR SHALL SAWSUCK AND FRODOCKE ENOUGH SELECT TOP SOIL TO ACCOMMODATE LANDSCAPING NEEDS.
- FOLLOWING STRIPPING AND GRUBBING, THE EXPOSED SOIL SHALL BE PROOF ROLLED TO REVEAL MAXIMUM GRADING OR OTHER UNSUITABLE SOILS. UNSUITABLE SOILS SHALL BE EXCAVATED TO FIRM GROUND AND FILLED TO GRADE WITH SATURATED NATIVE OR REPORTED STRUCTURAL FILL.
- EXPOSED SUBGRADE SOILS ON AREAS TO RECEIVE STRUCTURAL FILL SHALL BE SCRIPPED TO A DEPTH OF 8 INCHES.
- IF FILLS ARE NEEDED FOR STRUCTURAL SUPPORT, THEY SHALL BE INSTALLED IN NO MORE THAN 8-INCH LIFTS, AND SHALL BE COMPACTED TO AT LEAST 95% OF THE MAXIMUM DRY DENSITY FOR FINE GRAINED NATIVE SOILS UNLESS OTHERWISE SPECIFIED ON THE PLAN. THE TOP LIFT OF FILL SHALL BE COMPACTED TO 95% ALL OTHER SOILS SHALL BE COMPACTED TO NO LESS THAN 85%.
- COMPACTION TESTING SHALL BE DONE IN ACCORDANCE WITH ASTM D 698 (STANDARD PROCTOR).
- AT THE END OF THE GRADING OPERATION, THE STOCKPILED STRIPPINGS SHALL BE DISTRIBUTED ON THE LANDSCAPED AREAS IN A COMPACTED DEPTH NOT TO EXCEED 12".
- ALL SURFACES SHALL BE GRADED SMOOTH AND FREE OF IRREGULARITIES THAT MIGHT ACCUMULATE SURFACE WATER.
- ALL GRADING OPERATIONS ALONG DISTURBED SURFACES STABILIZATION SHALL BE IN ACCORDANCE WITH THE PROJECT EROSION CONTROL PLAN.

TRANSPORTATION

- THE MOST CURRENT EDITIONS OF THE WASHINGTON STATE DEPARTMENT OF TRANSPORTATION STANDARD DRAWINGS AND STANDARD DETAILS AND THE MOST CURRENT EDITIONS OF THE CITY OF RAYMOND DESIGN STANDARDS SHALL BE UTILIZED IN THE CONSTRUCTION OF TRANSPORTATION FACILITIES ON THESE PLANS.
- STREET SIGNING AND STRIPING SHALL BE INSTALLED BY THE DEVELOPER, ALL STREET SIGNS AND STRIPING SHALL BE INSTALLED PER THE LATEST ADOPTED EDITION OF THE MANUAL ON UNIFORM TRAFFIC CONTROL DEVICES (MUTCD) PUBLISHED BY THE U.S. DEPARTMENT OF TRANSPORTATION AND THE LATEST ADOPTED EDITIONS OF THE STATE OF OREGON SUPPLEMENT TO THE MUTCD.
- ALL CONSTRUCTION WITHIN THE RIGHT-OF-WAY SHALL HAVE AN APPROVED TRAFFIC CONTROL PLAN AND RIGHT-OF-WAY PERMIT PRIOR TO ANY ON-SITE CONSTRUCTION ACTIVITY.
- PAVING WITHIN THE PUBLIC RIGHT-OF-WAY WILL NOT BE ALLOWED DURING WET OR COLD WEATHER, PER DOT SPECIFICATIONS.
- ALL PAVEMENT SHALL BE STRAIGHT CUT PRIOR TO PAVING. EXISTING PAVEMENT SHALL BE REMOVED AS NECESSARY TO PROVIDE A SMOOTH TRANSITION FOR BOTH RIDE AND DRAINAGE.
- CONTRACTOR SHALL REPORT ALL DAMAGES IMMEDIATELY TO THE CITY'S PUBLIC WORKS DEPARTMENT OR CONTACT THE INSPECTOR ON THE JOB.
- PUBLIC RIGHTS-OF-WAY SHALL BE KEPT IN A CLEAN AND SERVICEABLE CONDITION AT ALL TIMES. IN THE EVENT MATERIALS ARE INADVERTENTLY DEPOSITED ON ROADWAYS, THE MATERIAL SHALL BE PROMPTLY REMOVED. MATERIALS MUST BE SWEEPED AND REMOVED WITH A VACUUM SUCKER.

STORM SEWER CONSTRUCTION

- ALL MATERIALS AND INSTALLATION OF STORM SEWERS AND DRAINAGE SYSTEMS SHALL BE IN ACCORDANCE WITH THE 2011 WASHINGTON STATE DEPARTMENT OF TRANSPORTATION STANDARD SPECIFICATIONS FOR ROAD, BRIDGE, AND MUNICIPAL CONSTRUCTION, WHEREVER THE STANDARD SPECIFICATIONS REFER TO THE "STATE," "SECRETARY," OR "WHEN REFERENCE IS MADE TO THE DEPARTMENT OF TRANSPORTATION IT SHALL BE UNDERSTOOD THAT THE STANDARD SPECIFICATIONS SHOULD READ THE "CITY," ADDITIONALLY, ALL MATERIALS AND INSTALLATION OF STORM SEWERS AND DRAINAGE SYSTEMS IN THE RIGHT OF WAY SHALL BE IN ACCORDANCE WITH THE REQUIREMENTS IN THE MOST CURRENT EDITIONS OF THE CITY OF RAYMOND DESIGN STANDARDS.
- PIPE LENGTHS SHOWN ON THE PLANS ARE TO THE CENTER OF THE STRUCTURE.
- PRE-PANED AS-BUILT'S ARE REQUIRED FOR STORMWATER, WATER, AND SANITARY FACILITIES. PROVIDE AS-BUILT INFORMATION TO THE CONSTRUCTION INSPECTOR AND CONSTRUCTION ENGINEER FOR APPROVAL PRIOR TO ANY DIGGING.
- MATERIALS FOR STORM SEWER STREET LATERALS AND LANS SHALL BE DUAL-WALLED, SMOOTH INTERIOR, CORRUGATED POLYETHYLENE STORM SEWER PIPE UNLESS OTHERWISE SPECIFIED ON PLANS.
- SEE THE WSDOT STANDARD SPECIFICATIONS FOR ROAD, BRIDGE, AND MUNICIPAL CONSTRUCTION, DIVISION 7 FOR STORM SEWER PIPE MATERIALS AND PLANS.
- CATCH BASINS SHALL BE TYPE 1 OR PROJECT APPROVED EQUAL, UNLESS OTHERWISE SPECIFIED ON PLANS.
- TRENCH EXCAVATION SHALL MEET THE REQUIREMENTS OF WSDOT STANDARD SPECIFICATIONS FOR ROAD, BRIDGE, AND MUNICIPAL CONSTRUCTION.

- STORM SEWER PIPE BEDDING MATERIAL SHALL PROVIDE UNIFORM SUPPORT ALONG THE ENTIRE PIPE BARREL, WITHOUT LOAD CONCENTRATION AT JOINT COLLARS OR REELS. PIPE ZONE BEDDING SHALL BE CLEAN EARTH OR SAND, FREE FROM CLAY, FRESH LUMPS, ROOTS, OR MOISTURE IN EXCESS OF THAT PERMITTED REQUIRED COMPACTION.
- PIPE BEDDING MATERIALS SHALL IN ACCORDANCE WITH SECTION 9.03.12(C) PIPE BACKFILL. PIPE ZONE BEDDING SHALL BE PLACED IN LAYERS AND COMPACTED TO 90 PERCENT MAXIMUM DENSITY.
- STORM SEWER JUNCTIONS, AS NOTED ON THE PLANS, SHALL BE FITTED WITH AN APPROVED TRAP.

SANITARY SEWER CONSTRUCTION

- SANITARY SEWER LATERALS SHALL BE 4" IN SIZE, INSTALLED AT A MINIMUM SLOPE OF 0.0045 FT/FT UNLESS OTHERWISE SPECIFIED ON THE PLAN.
- MATERIALS FOR SANITARY SEWER PIPE SHALL BE PVC PIPE CONFORMING TO ASTM D2688 OR GREEN COLOR DRED PVC, C905 OR 14, HOPE PIPE OR 21, OR DUCTILE IRON, AS NOTED ON THE PLANS.
- PIPE LENGTHS SHOWN ON THE PLANS ARE TO THE CENTER OF THE STRUCTURE.
- SANITARY SEWER PIPE BEDDING AND BACKFILL SHALL MEET THE REQUIREMENTS OF SECTION 9.03.12(C), NATIVE BACKFILL MAY BE USED UPON APPROVAL FROM THE INSPECTOR. SANITARY SEWER PIPE SHALL BE INSTALLED IN ACCORDANCE TO THE TRENCH BACKFILL, BEDDING, PIPE ZONE, AND MULTIPLE INSTALLATIONS STANDARD DETAIL.
- CONTRACTOR TO MAINTAIN A MINIMUM 18" HORIZONTAL AND 18" VERTICAL SEPARATION BETWEEN ALL EXISTING AND PROPOSED WATER AND SANITARY SEWER LINES.
- ALL SANITARY MANHOLES SHALL BE 48" Ø UNLESS OTHERWISE SPECIFIED ON PLANS.
- LOCATOR TAPE TO BE LOCATED EIGHTEEN (18) INCHES ABOVE A SERVICE MAIN AND TWELVE (12) INCHES ABOVE A SERVICE LINE.
- THE LOCATOR TAPE SHALL BE MARKED WITH CONTINUOUS THREE (3) INCH WIDE GREEN SIX (6) MIL THICK LOCATOR TAPE THREE (3) INCH HIGH BLACK LETTERS EVERY THREE (3) FEET WITH "MARKING - BURIED SANITARY SEWER".
- A CONTINUOUS TONING WIRE SHALL BE ATTACHED TO THE TOP OF THE SANITARY SEWER SERVICE LINE. THE TONING WIRE SHALL BE COATED #14 AWG (MIN.) SOLID COPPER WIRE, OR APPROVED EQUAL. THE TONING WIRE SHALL END IN THE VALVE BOX WITH A MINIMUM OF ONE (1) FOOT COILED WIRE. THE TONING WIRE SHALL BE TESTED FOR CONTINUITY PRIOR TO ACCEPTANCE. ALL SPLICES WILL BE SOLDERED A MINIMUM TWO (2) INCHES IN LENGTH AND ENCASED WITH 3M SCOTCH 8228 VINYL MASTIC TAPE (3/4" BY 4") OR 3M SCOTCH 39 ELECTRICAL TAPE AND COATED WITH SCOTCH NOTE ELECTRICAL COATING 21448 (RED-TEX) PROCESS AFTER FIRST COATING DRIES, OR APPROVED EQUAL.

WATER SYSTEM CONSTRUCTION

- MATERIALS FOR WATER PIPES SHALL BE DUCTILE IRON CL 60 OR PVC PIPE CONFORMING TO PVC-C900 OR 25, UNLESS OTHERWISE SPECIFIED ON PLANS.
- PIPE BEDDING MATERIALS SHALL IN ACCORDANCE WITH SECTION 9.03.12(C) PIPE BACKFILL. PIPE ZONE BEDDING SHALL BE PLACED IN LAYERS AND COMPACTED TO 90 PERCENT MAXIMUM DENSITY.
- CONTRACTOR TO MAINTAIN A MINIMUM 18" HORIZONTAL AND 18" VERTICAL SEPARATION BETWEEN ALL EXISTING AND PROPOSED WATER AND SANITARY SEWER LINES.
- ANY SIGNIFICANT DEVIATION FROM THE PLANS WILL REQUIRE REQUEST FROM THE APPLICANT'S ENGINEER AND APPROVAL FROM THE CITY'S ENGINEER AND CITY INSPECTOR.

BACKFLOW PREVENTION DEVICE NOTES

- ALL COMMERCIAL WATER METER SHALL BE PROTECTED WITH A STATE-APPROVED BACKFLOW DEVICE.
- STATE APPROVED BACKFLOW PROTECTION SHALL BE REQUIRED ON FIRE SPRINKLER AND IRRIGATION SYSTEMS. ALL POSSIBLE SHALL BE PROTECTED WITH VACUUM BREAKER 5. FURTHER BACKFLOW PREVENTION SHALL BE REQUIRED DEPENDING ON WATER USAGE IE - BOILERS, CHILLERS, CHEMICAL ADDITION S, BOOSTER PUMPS, FUEL FIC.



190 COURNOUD STREET
NEWTON, MA 02459
WWW.AECCONET

RV PARK PRELIMINARY DESIGN

622 HEATH STREET
RAYMOND, WASHINGTON 98577

NO.	REVISED	DATE	DESCRIPTION

CLIENT: **Civitas**
 DRAWN BY: **gboer**
 CHECKED BY: **gboer**
 SCALE:
 DRAWING NOT TO SCALE
 SHEET TITLE:
CONSTRUCTION NOTES
 SHEET NO.: **SO.1**

 12. 21. 13
PERMITTING PLAN SET

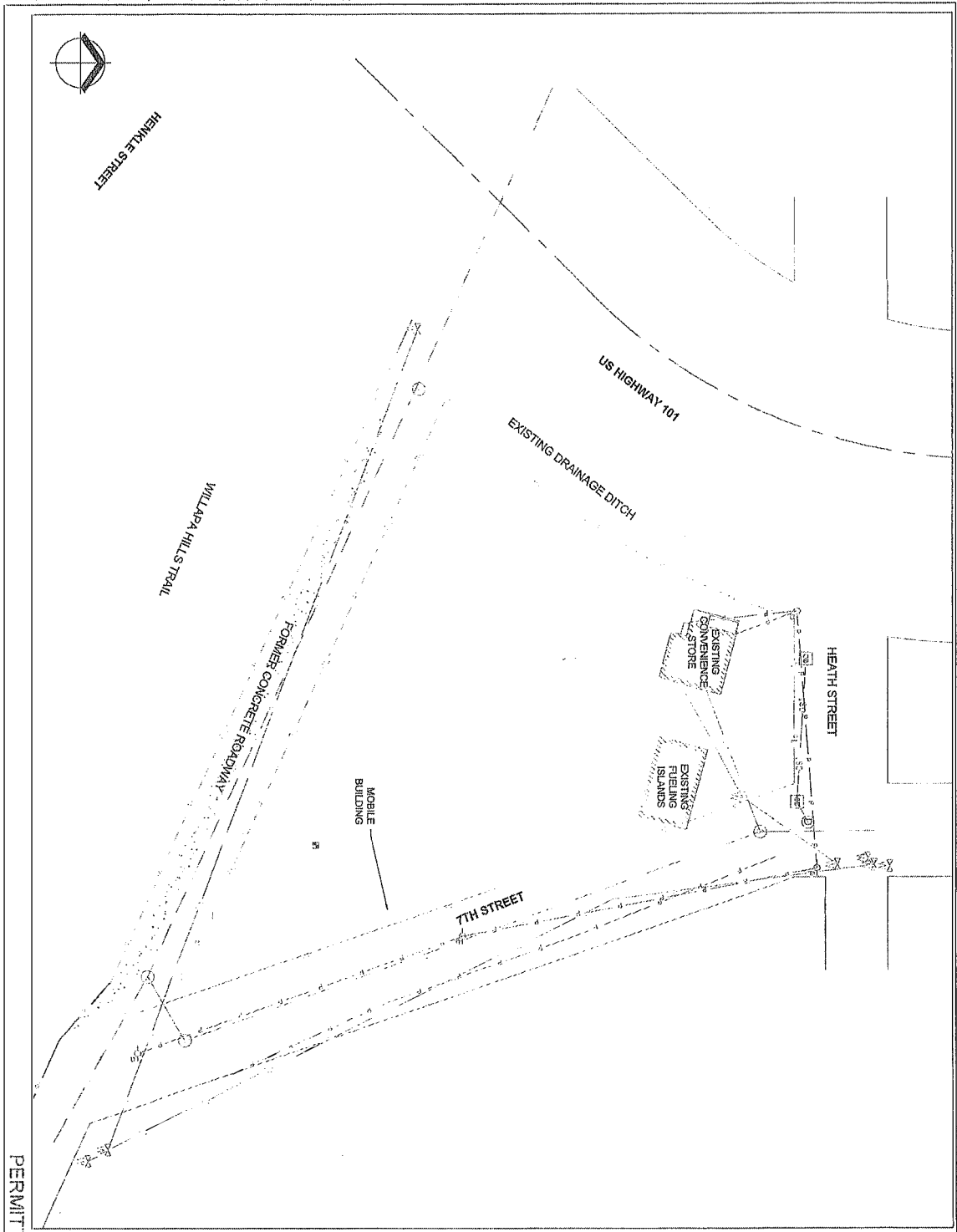

PROJECT	S1.0
SHEET	EXISTING CONDITIONS PLAN
DATE	07/26/22
SCALE	AS SHOWN
DESIGNED BY	
CHECKED BY	
APPROVED BY	
DATE	
ISSUE	
DATE	
DESCRIPTION	

RV PARK PRELIMINARY DESIGN
 622 HEATH STREET
 RAYMOND, WASHINGTON 98577

AEC
 705 COLORADO STREET
 KELSO, WASHINGTON 98626
 360.577.9104
 WWW.AECLUG.NET



RV PARK PRELIMINARY DESIGN

622 HEATH STREET
RAYMOND, WASHINGTON 98677

NO.	REVISION/DATE

CLIENT: AMIWA
DRAWN BY: GROSSY
CHECKED BY: GROSSY
SCALE:



SHEET TITLE
SITE PLAN
SHEET S2.0

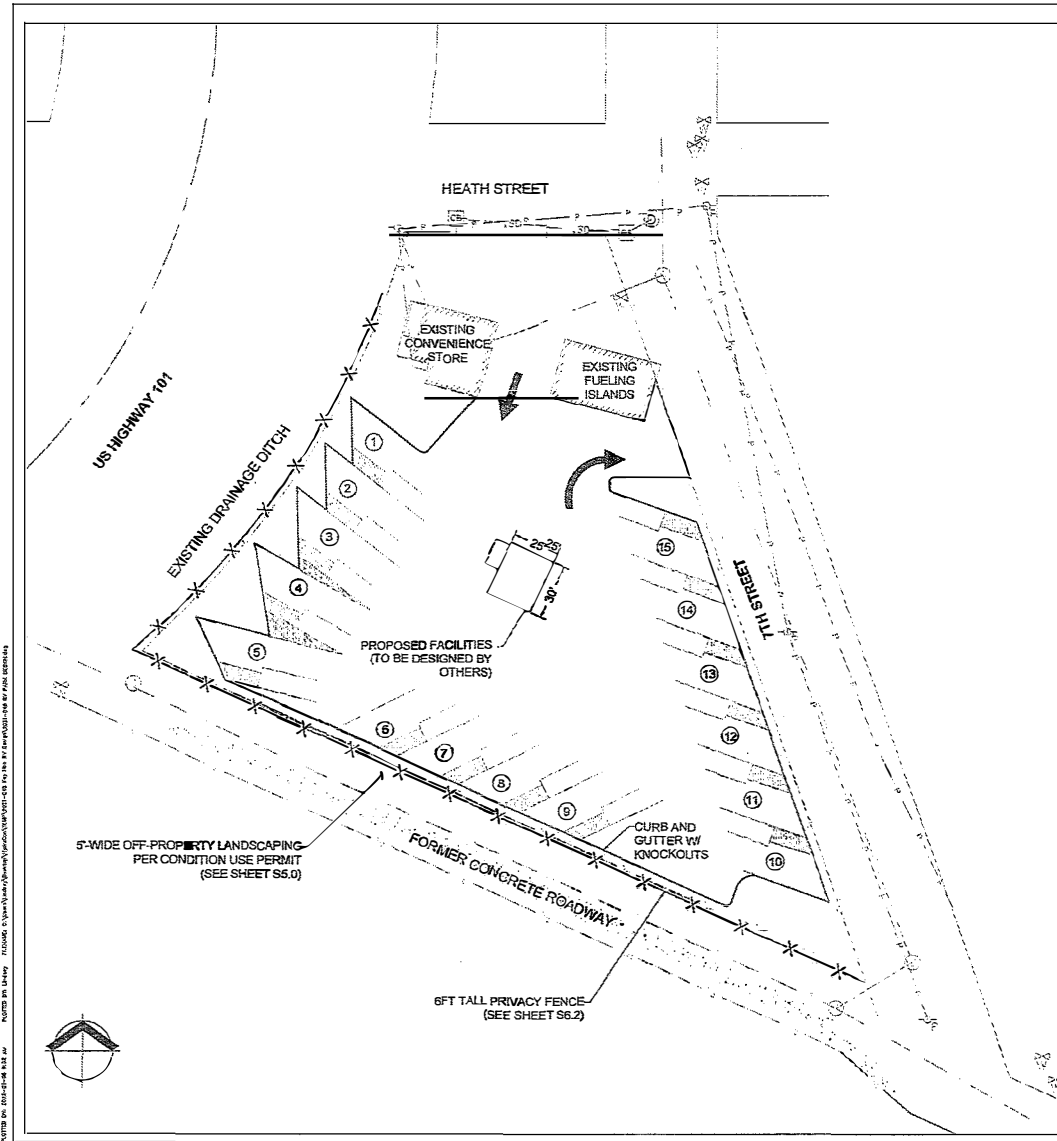

- ### NOTES
- 1. ALL RV SPACES ARE LOCATED WITHIN 300FT OF EXISTING FACILITIES
 - 2. ALL RV SPACES ARE MIN. 5FT FROM EXISTING ROADWAYS
 - 3. INDIVIDUAL RV STAY TO BE LIMITED TO 90-DAYS IN ANY 180-DAY PERIOD PER CONDITIONAL USE PERMIT

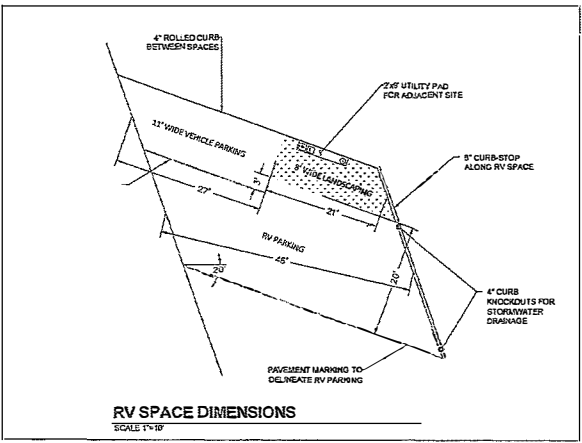

PERMITTING PLAN SET

DATE: 05/21/2024 11:48 AM
PROJECT: 24-100915
DRAWING: 24-100915-03.RVT
SHEET: S2.0



RV PARK P PRELIMINARY DESIGN

6 22 HEATH STREET

RAY MOND, WASHINGTON 98877

NO.	REVISION/DESCRIPTION	DATE

DATE: 05/12/13
DRAWN: CREDIT
CHECKED: A. GILSON
SCALE:

DRAWING NOT TO SCALE

SHEET TITLE
DETAILS II

SHEET
S6.1

DIAM.	MIN. WALL THICKNESS	MIN. BASE THICKNESS	MAXIMUM KNOCKOUT SIZE	MINIMUM DISTANCE BETWEEN KNOCKOUTS
48"	4"	6"	36"	8"

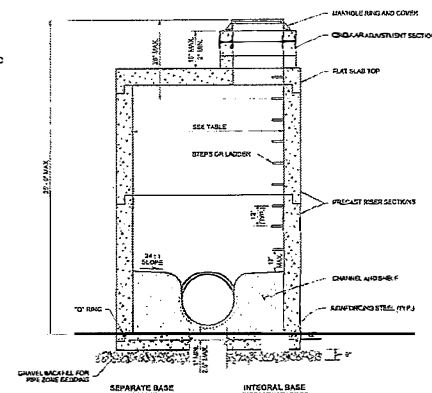

WSDOT TYPE 3 MANHOLE

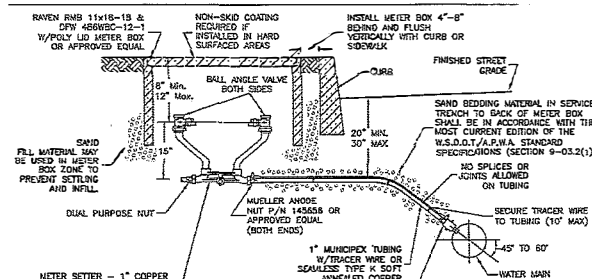

- NOTES:
1. ALL DOMESTIC AND IRRIGATION METERS SHALL BE SUPPLIED, OWNED AND INSTALLED BY THE CITY OF VANCOUVER PER VMC 14.04.170(3)
 2. ALL METERS 2" AND LESS SHALL BE THE ROTATING DISC TYPE. TURBINE METERS ARE NOT ALLOWED.
 3. PRIOR TO CITY INSTALLATION OF METERS, ALL SERVICE APPLICATIONS MUST BE COMPLETED AND APPROVED. SERVICE FEES PAID IN FULL AND 45-DNATS SUBMITTED AND APPROVED.
 4. CONTRACTOR SHALL CONTACT CITY CONSTRUCTION MANAGER'S OFFICE (360) 487-7750 48 HOURS PRIOR TO INSTALLING ANY WATER SERVICE CONNECTIONS.
 5. METERS WILL NOT BE SET BY THE CITY PRIOR TO DISINFECTION OF THE MAIN AND SERVICE, AND PRIOR TO A SUCCESSFUL BACTERIOLOGICAL TEST.
 6. WATER SERVICES SHALL BE PRESSURE TESTED ALONG WITH THE MAIN.
 7. DURING THE PRESSURE TEST, THE MAIN SHALL BE OPEN FOR INSPECTION AT ALL CORPORATIONS.
 8. METER BOX SHALL NOT BE ALLOWED IN HARD SURFACE AREAS WITHOUT PRIOR CITY OF VANCOUVER WRITTEN APPROVAL.
 9. ALL SERVICES ARE SUBJECT TO REVIEW FOR BACKFLOW PROTECTION REQUIREMENTS.
 10. ALL SINGLE FAMILY LOTS 50' AND WIDER SHALL PLACE THE SERVICES AND METER BOXES ALONG THE PROPERTY FRONTAGE NEAR THE CENTER OF THE LOT LINE.
 11. ALL SERVICE REPLACEMENTS MUST TERMINATE AT EITHER A NEW YOKE, AN ANGLE STOP OR A CURB STOP. NEW ANGLE OR CURB STOPS SHALL BE MUELLER 110 FITTINGS OR APPROVED EQUAL.
 12. A MAXIMUM OF ONE FITTING (MUELLER 110 3 PART COMPRESSION + COMPRESSION, OR APPROVED EQUAL) SHALL BE ALLOWED BETWEEN THE CORP. STOP AND THE METER SET ON ALL SERVICE TRANSFERS.
 13. DIRECT SERVICE TAPS ARE ONLY ALLOWED ON 6" DI AND LARGER. ALL OTHER MUST USE A SERVICE SADDLE.
 14. TRACER WIRE IS REQUIRED ON ALL MUNIPEX TUBING AND SHALL BE COPPERHEAD 1030 COPPER COATED STEEL WIRE DESIGNED FOR DIRECT BURY APPLICATIONS OR APPROVED EQUAL.
 15. COMPRESSION FITTINGS WITH STAINLESS STEEL INSERTS SHALL BE USED ON ALL CONNECTIONS TO MUNIPEX TUBING.
 16. TRACING WIRE SHALL NOT BE SPLICED AND SHALL BE TESTED FOR CONTINUITY PRIOR TO ACCEPTANCE.

N.T.S.

N.T.S.

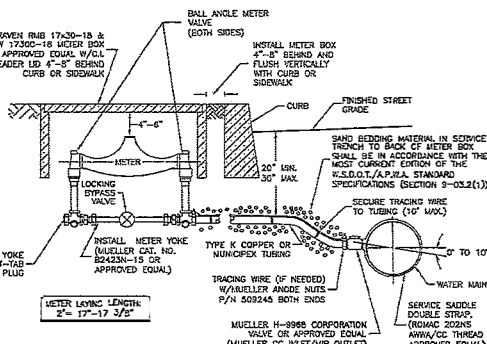

- NOTES:
1. ALL DOMESTIC AND IRRIGATION METERS SHALL BE SUPPLIED, OWNED AND INSTALLED BY THE CITY OF VANCOUVER PER VMC 14.04.170(3)
 2. ALL METERS 2" AND LESS SHALL BE THE ROTATING DISC TYPE. TURBINE METERS ARE NOT ALLOWED.
 3. PRIOR TO CITY INSTALLATION OF METERS, ALL SERVICE APPLICATIONS MUST BE COMPLETED AND APPROVED. SERVICE FEES PAID IN FULL AND 45-DNATS SUBMITTED AND APPROVED.
 4. CONTRACTOR SHALL CONTACT CITY CONSTRUCTION MANAGER'S OFFICE (360) 487-7750 48 HOURS PRIOR TO INSTALLING ANY WATER SERVICE CONNECTIONS.
 5. METERS WILL NOT BE SET BY THE CITY PRIOR TO DISINFECTION OF THE MAIN AND SERVICE, AND PRIOR TO A SUCCESSFUL BACTERIOLOGICAL TEST.
 6. WATER SERVICES SHALL BE PRESSURE TESTED ALONG WITH THE MAIN.
 7. DURING THE PRESSURE TEST, THE MAIN SHALL BE OPEN FOR INSPECTION OF ALL CORPORATIONS STOPS.
 8. USE 1-7/8" BIT FOR ALL 2" SADDLE TAPS.
 9. METER BOX SHALL NOT BE ALLOWED IN HARD SURFACE AREAS WITHOUT PRIOR CITY OF VANCOUVER WRITTEN APPROVAL. IF METER BOX MUST BE LOCATED IN A WALKING AREA, A NON-SKID TRAFFIC RATED LID SHALL BE REQUIRED.
 10. METERS PLACED IN HARD SURFACED AREAS SHALL BE CALLED OUT AS SUCH ON THE PLANSET.
 11. ALL SERVICES ARE SUBJECT TO REVIEW FOR BACKFLOW PROTECTION REQUIREMENTS.
 12. ALL 1-1/2" AND 2" METER INSTALLATIONS SHALL BE 2" TAPS AND 2" SERVICE PIPING.
 13. TRACER WIRE IS REQUIRED ON ALL MUNIPEX TUBING AND SHALL BE COPPERHEAD 1030 COPPER COATED STEEL WIRE DESIGNED FOR DIRECT BURY APPLICATIONS OR APPROVED EQUAL.
 14. COMPRESSION FITTINGS WITH STAINLESS STEEL INSERTS SHALL BE USED ON ALL CONNECTIONS TO MUNIPEX TUBING.
 15. TRACING WIRE SHALL NOT BE SPLICED AND SHALL BE TESTED FOR CONTINUITY PRIOR TO ACCEPTANCE.

2" WATER SERVICE

1" WATER SERVICE

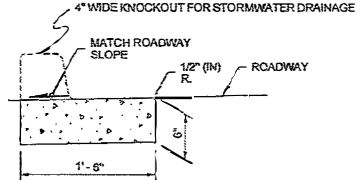
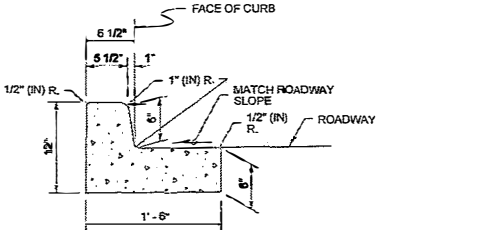

CONCRETE CURB AND GUTTER W/ DRAINAGE KNOCKOUT

PERMITTING PLAN SET

DATE: 05/12/13 10:48:58 AM PLOTTED: C:\Users\jgibson\Documents\Projects\2013\13-000000-0000\13-000000-0000.dwg BY: JGIBSON

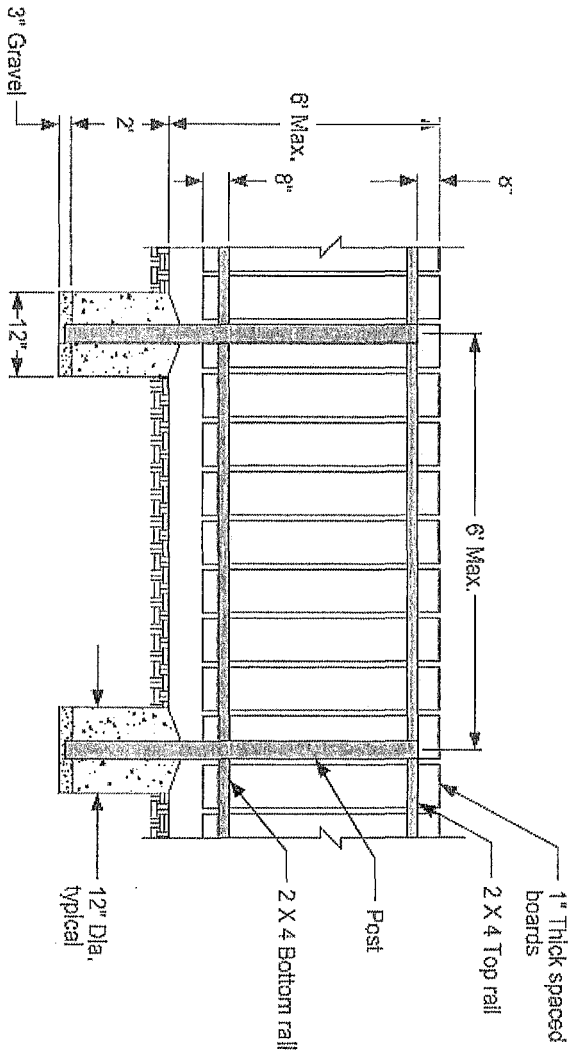

- 1. ALL WOOD MATERIAL SHALL BE TREATED WITH AN ACCEPTED PRESERVATIVE.
- 2. ALL CONCRETE SHALL BE CLASS 3000 MINIMUM.
- 3. ALL REINFORCEMENT SHALL BE #4 BARS.
- 4. ALL DIMENSIONS SHALL BE UNLESS OTHERWISE SPECIFIED.
- 5. ALL DIMENSIONS SHALL BE UNLESS OTHERWISE SPECIFIED.
- 6. ALL DIMENSIONS SHALL BE UNLESS OTHERWISE SPECIFIED.

PERMITTING PLAN SET



PROJECT NO.	10474746
DATE	02/26/10
DESCRIPTION	RV PARK PRELIMINARY DESIGN
SCALE	AS SHOWN
DESIGNED BY	JPH
CHECKED BY	JPH
DATE	02/26/10
DESCRIPTION	RV PARK PRELIMINARY DESIGN
SCALE	AS SHOWN
DESIGNED BY	JPH
CHECKED BY	JPH
DATE	02/26/10
DESCRIPTION	RV PARK PRELIMINARY DESIGN

RV PARK PRELIMINARY DESIGN
 622 HEATH STREET
 RAYMOND, WASHINGTON 98577

2022 Council Committees/Members

1. Budget and Finance
 - a. Chris
 - b. Ryan
 - c. Heidi
2. PW & Community Development
 - a. Karen
 - b. Tony
3. Public Health and Safety
 - a. Ian
4. RWCC
 - a. Ryan
 - b. Mayor